



Gas safety checklist for caterers, food outlets and others at public venues

Complete this checklist before the start of the event. All questions should be answered as accurately as possible.

If it appears that you have an unsafe gas installation, seek assistance from a licensed gas fitter. Building and Energy can provide advice to event organisers about gas safety.

Building and Energy may carry out on site gas safety inspections of gas appliances before and during use in public venues to ensure compliance with the Act, Regulations and Australian Standards. Building and Energy can require immediate correction of any unsafe condition. If you fail to comply with the Act or Regulations Building and Energy may issue an Infringement Notice, Notice of Defect or Inspectors Order with significant penalties.

How to complete the check list

Start at the gas meter for natural gas and at the LP Gas cylinders for a LP Gas supply and proceed towards the gas appliances.

Answer each question if the situation is appropriate. The preferred answer is indicated by a shaded box.

If the answer to a question is not the preferred one, the remedy may be quite simple. For example, a cylinder obstructing an exit should be moved.

If you are unsure about a question or an answer, contact Building and Energy on 6251 1900.

When the check list is completed

Please give the original checklist to the site administrator and keep a copy for the duration of the event. You may be requested to produce it as part of a site safety audit. Make sure any remedial work is carried out **before** the event commences.

Guide to gas installations

Fixed gas appliances and pipe work must only be installed by a licensed gas fitter, who must:

- provide a Notice of Completion;
- produce their licence on request; and
- attach a compliance badge to the installation.

If a gas leak is suspected:

- turn off appliances;
- turn off gas supply;
- do not use any ignition sources; and
- seek assistance.

Note

To obtain copies of the checklist, you can:

- photocopy this document;
- download it from the website:
www.dmirs.wa.gov.au/energysafety; or
- telephone 6251 1900 for additional copies.

Checklist – please print clearly	
Event:	
Venue or site administrator	
Contact person's name:	Ph:
Event organiser	
Contact person's name:	Ph:
Responsible person nominated for venue or site at event	
Contact person's name:	Ph:
Vendors and any other gas consumers at event	
Business name:	
Location of business at the event:	
Type of business structure (caravan, marquee etc):	
Responsible business person's name:	Ph:
Business name:	
Location of business at the event:	
Type of business structure (caravan, marquee etc):	
Responsible business person's name:	Ph:
Business name:	
Location of business at the event:	
Type of business structure (caravan, marquee etc):	
Responsible business person's name:	Ph:
Person completing checklist	
Venue or site administrator/event organiser/vendor/other (Circle which applies)	
Name:	Ph:

For gas technical advice:

Phone: 6251 1900 Fax: 6251 1901

www.dmirs.wa.gov.au/energysafety

Gas appliances

Checklist	Yes	No
Are gas appliances designed to be used outdoors (barbecues and the like) installed outdoors?		
Are indoor gas appliances to be used and is there adequate ventilation and fluing?		
If commercial gas appliances are to be used, then are they fitted with exhaust hoods or canopies installed to local building requirements?		
Have appliances been checked within the last 12 months by a qualified person?		
Have additions or alterations been made to the installation since the last check?		
Are appliances labelled with an AGA, SAI Global, IAPMO R&T Oceana or EnergySafety approval badge?		
Have safety devices been tampered with? (If unsure contact a gas fitter)		
Do thermostats work?		
Do ignition devices work?		
Are supply pipes or hoses in good condition?		
Have joints been tested for gas leakage with soapy water?		
Are combustible materials and customers clear of appliance?		
Are combustible surfaces within the distances shown in the illustration below?		

See required clearances below.

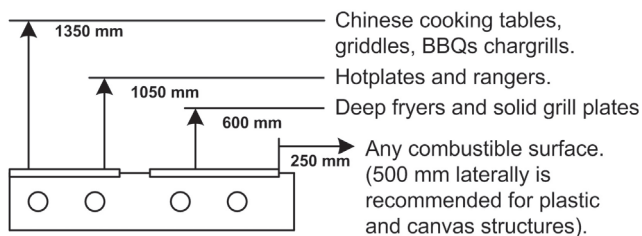

Gas cylinders (LP Gas installations only)

Checklist	Yes	No
Are gas cylinders damaged, rusty or over 10 years old?		
Are cylinders in use situated outside the caravan or structure?		
Are spare cylinders, full or empty, stored externally?		
Are cylinders blocking an exit?		
Are cylinders on a level, non-combustible surface?		
Are cylinders secured in an upright position?		
Are cylinders in a well ventilated position?		
Is cylinder safety outlet facing away from the structure?		
Are cylinders protected from tampering?		
Is the area shown below clear of ignition sources?		

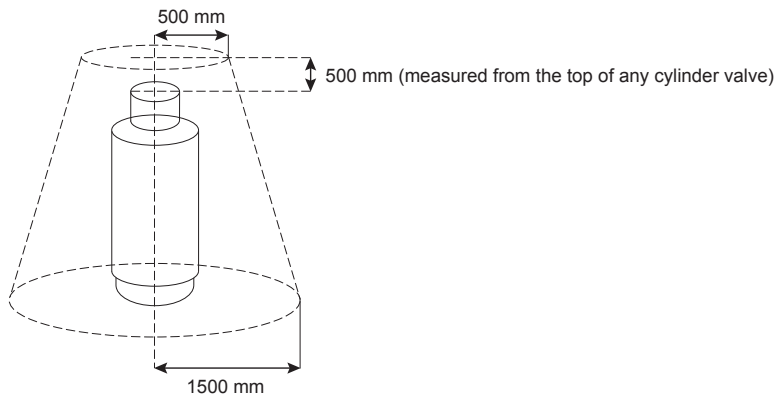

Safety procedures

Checklist	Yes	No
Do staff know what to do in an emergency?		
Is there a suitable fire extinguisher handy?		
Has someone been trained to exchange gas cylinders? (LP Gas installations only).		